



Office de la Propriété  
Intellectuelle  
du Canada  
Un organisme  
d'Industrie Canada

Canadian  
Intellectual Property  
Office  
An agency of  
Industry Canada

**Registration Number:**  
**Date of Registration:**

**163369**  
**2016-02-12**

**RADAR ENHANCED PARKING METER**

Applicant(s) as Filed: **IPS Group, Inc.**

**Description:**

The Design consists of the features of shape, configuration, and ornament of the RADAR ENHANCED PARKING METER as shown in solid lines in the drawings. Portions shown in stippled lines do not form part of the design. Drawings of the Design are included, in which: Figure 1 is a front perspective view of a RADAR ENHANCED PARKING METER; Figure 2 is a front elevational view thereof; Figure 3 is a rear elevational view thereof; Figure 4 is a left side elevational view thereof; Figure 5 is a right side elevational view thereof; Figure 6 is a top plan view thereof; and Figure 7 is a rear perspective view thereof.

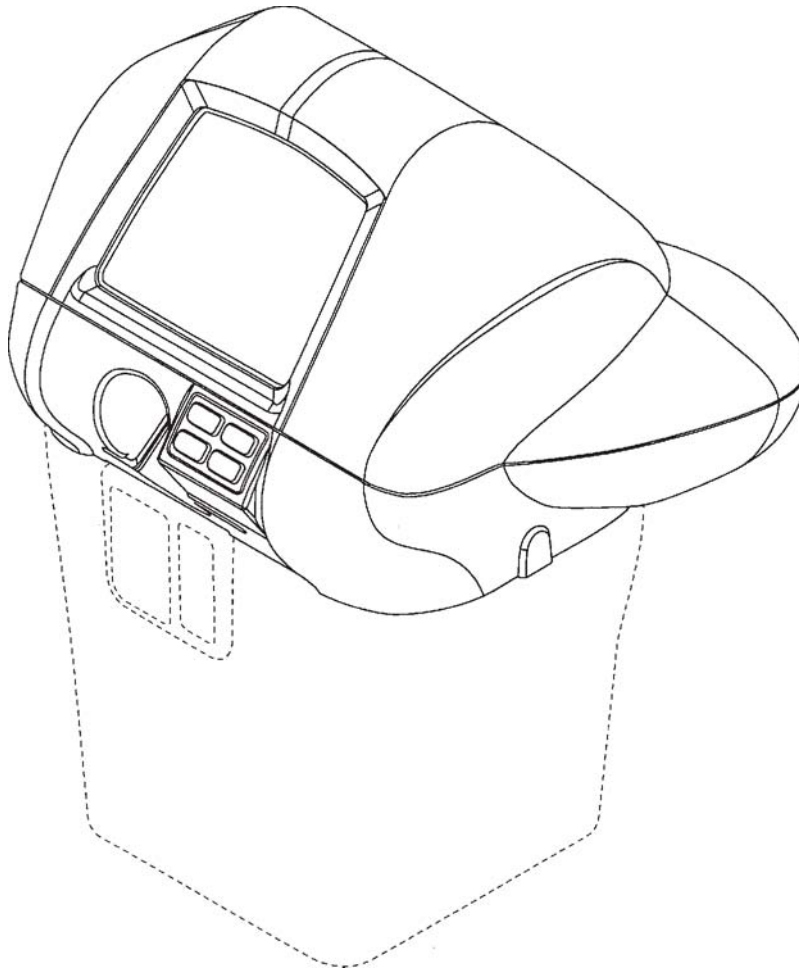

# Details

## Third-Party Information Liability Disclaimer

Some of the information on this Web page has been provided by external sources. The Government of Canada is not responsible for the accuracy, reliability or currency of the information supplied by external sources. Users wishing to rely upon this information should consult directly with the source of the information. Content provided by external sources is not subject to official languages, privacy and accessibility requirements.

**National Application/Registration** : 163369

**Date of Registration** :

2016-02-12

**Made available on** :

2016-02-12

**Status** :

Registered

---

**Title or finished article**: RADAR ENHANCED PARKING METER

**Canadian Classification**:

10-03-OTHER TIME-MEASURING INSTRUMENTS

**Other Classes Searched**:

N/A

---

**Description**:

The Design consists of the features of shape, configuration, and ornament of the RADAR ENHANCED PARKING METER as shown in solid lines in the drawings. Portions shown in stippled lines do not form part of the design. Drawings of the Design are included, in which: Figure 1 is a front perspective view of a RADAR ENHANCED PARKING METER; Figure 2 is a front elevational view thereof; Figure 3 is a rear elevational view thereof; Figure 4 is a left side elevational view thereof; Figure 5 is a right side elevational view thereof; Figure 6 is a top plan view thereof; and Figure 7 is a rear perspective view thereof.

---

**Statement**:

N/A

---

**Interested Parties**

**Applicant(s) as Filed**:

IPS GROUP, INC.

**Registered Proprietor(s)**:

IPS GROUP, INC.  
5601 OBERLIN DRIVE, SUITE 100  
SAN DIEGO, 92121  
CALIFORNIA, UNITED STATES OF AMERICA

**Proprietor(s):**

IPS GROUP INC.  
7737 KENAMAR COURT  
SAN DIEGO, 92121  
CALIFORNIA, UNITED STATES OF AMERICA

**Client Reference Number:**

83472-44

**Representative for Service:**

SMART & BIGGAR LLP  
2300-1055 WEST GEORGIA BOX 11115  
VANCOUVER, V6E 3P3  
BRITISH COLUMBIA, CANADA

**Agent:**

SMART & BIGGAR LLP  
2300-1055 WEST GEORGIA BOX 11115  
VANCOUVER, V6E 3P3  
BRITISH COLUMBIA, CANADA

---

**Registration Expiry date (Subject to payment of a maintenance fee):** 10 years

**Maintenance Fee Paid:**

No

**Filing Date:**

2015-07-08

**Correction(s):**

No

**Priority Claim(s):**

Third-Party Information Liability Disclaimer

1/7

**FIG. 1**

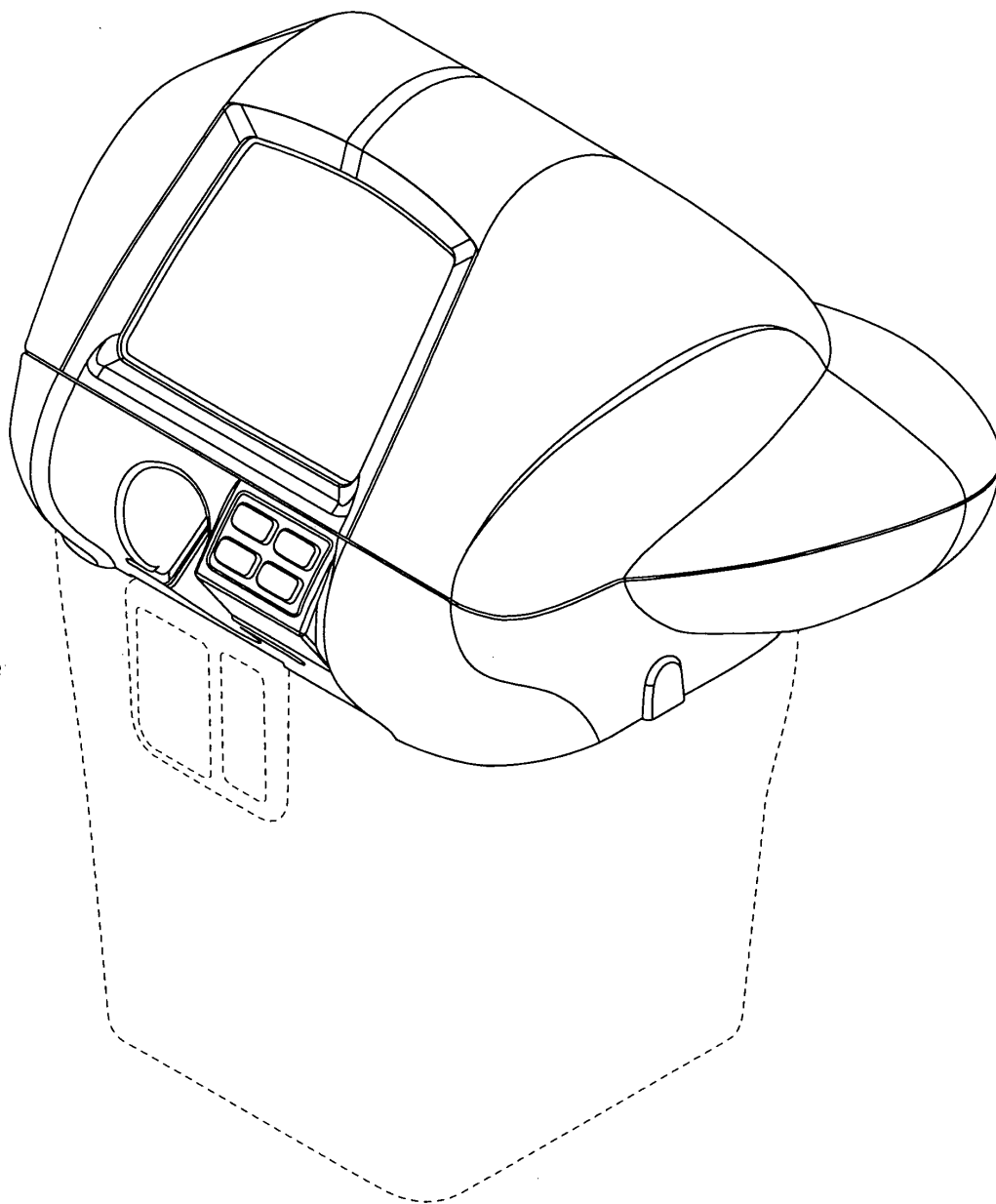

2/7

**FIG. 2**

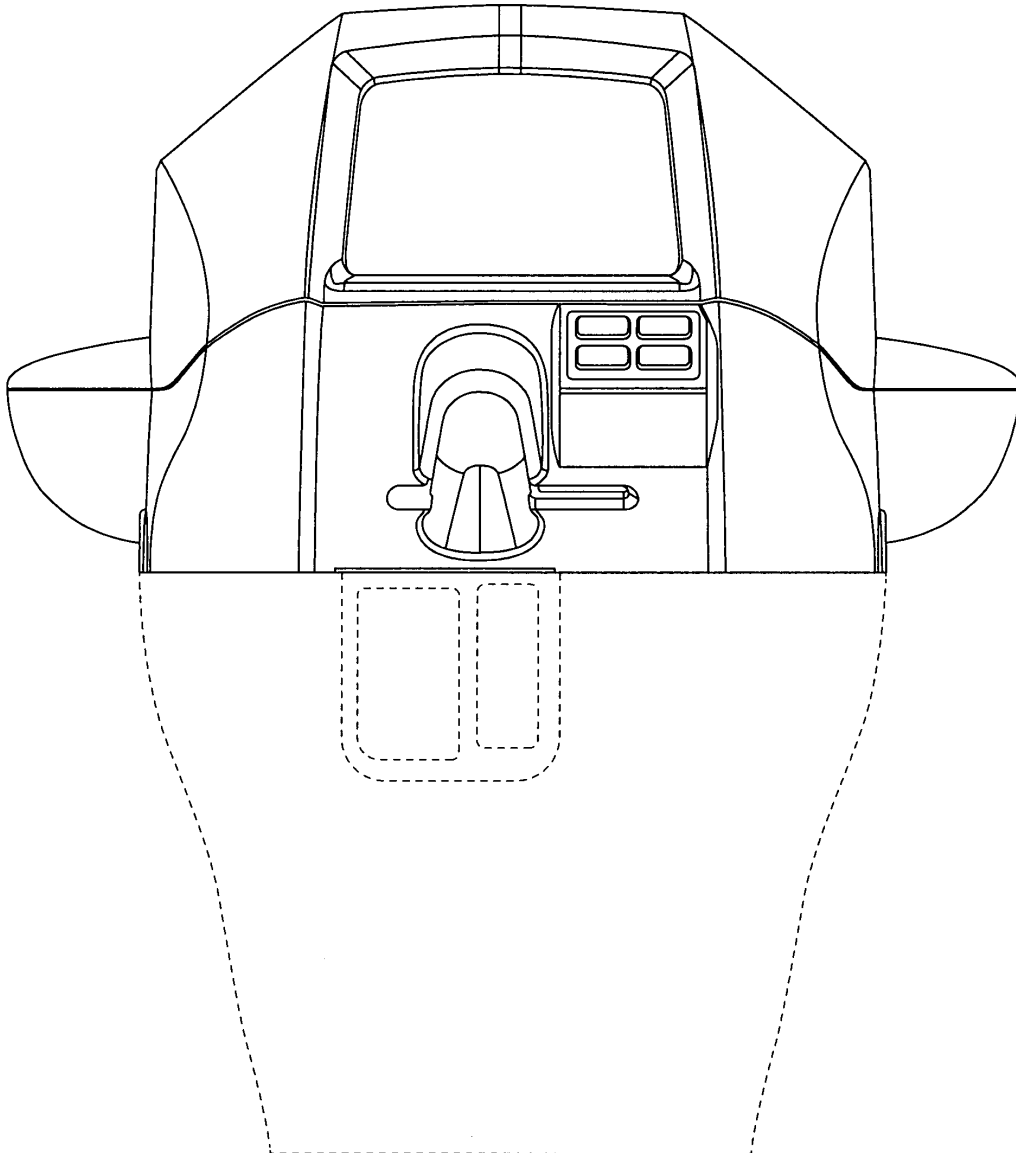

3/7

**FIG. 3**

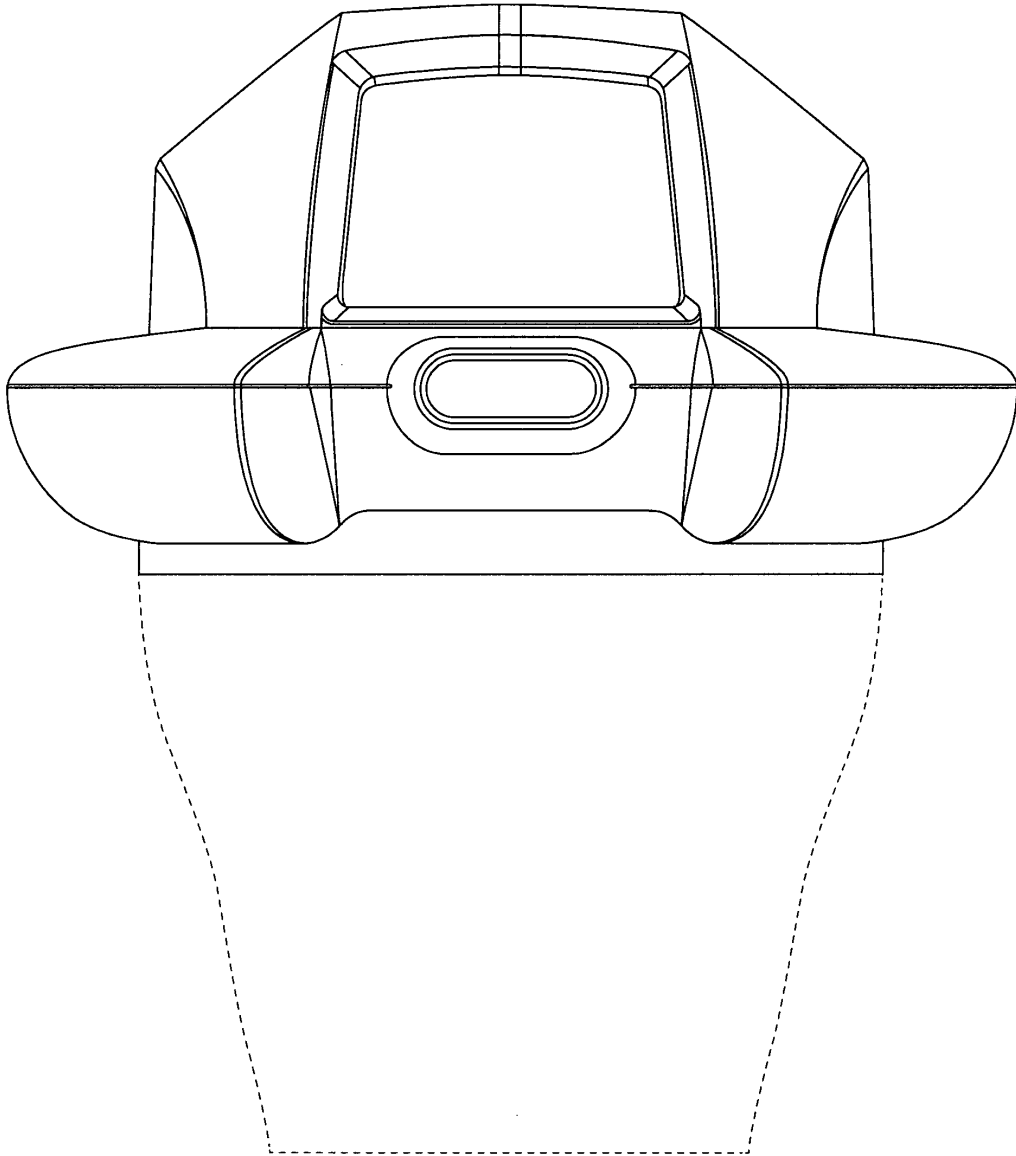

4/7

**FIG. 4**

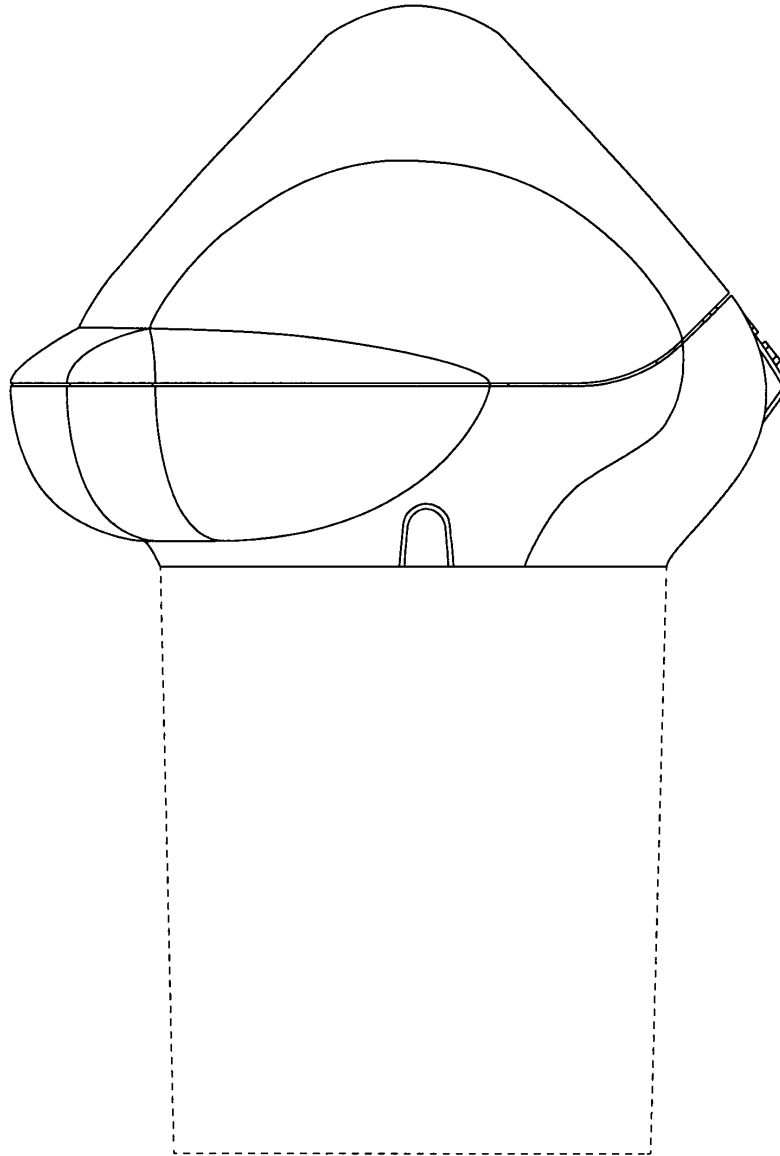

5/7

**FIG. 5**

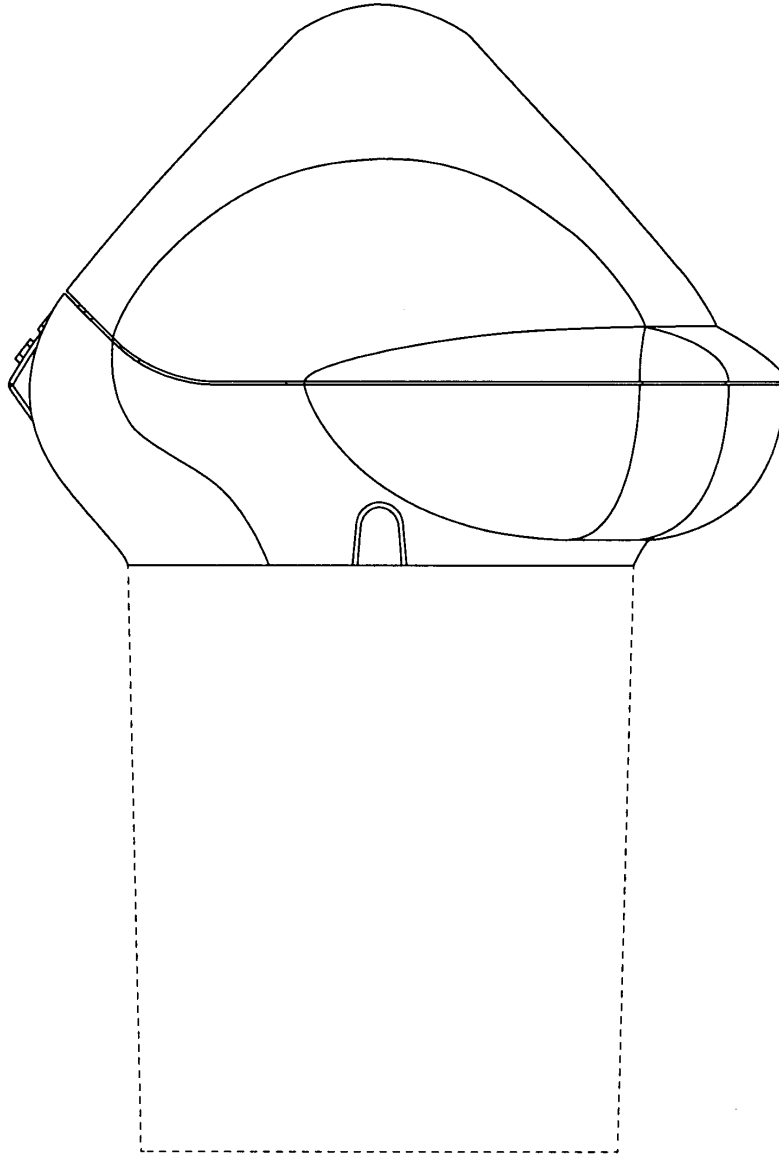



6/7

**FIG. 6**

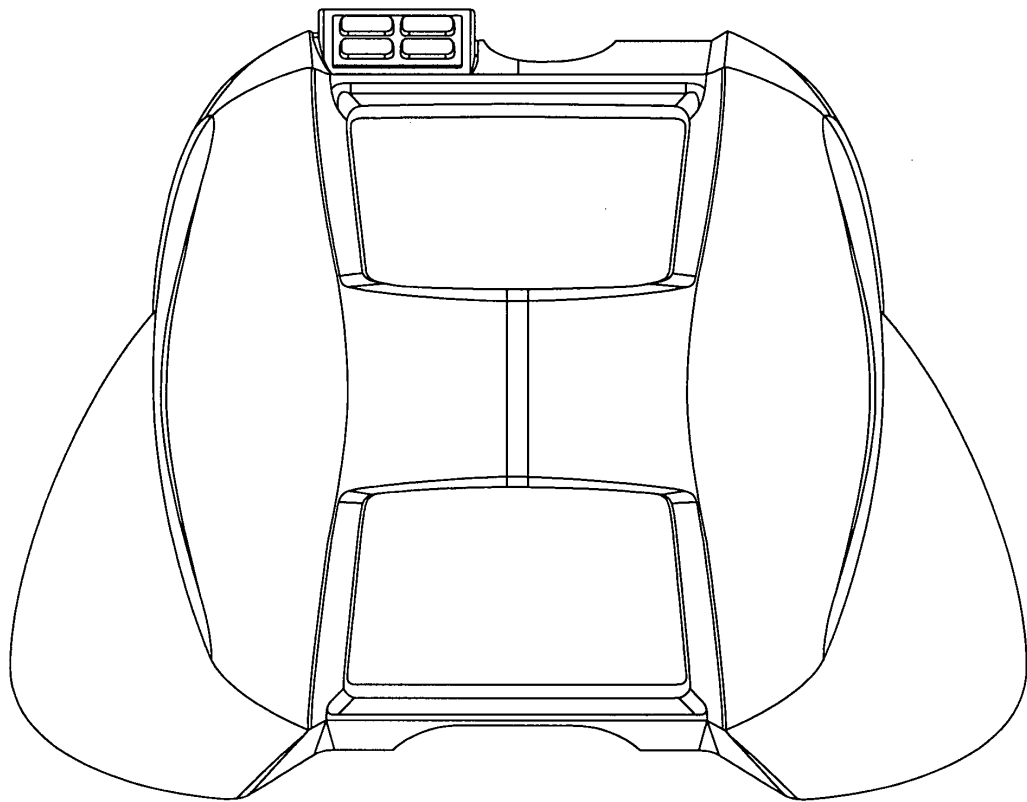

7/7

**FIG. 7**

