



Office de la Propriété
Intellectuelle
du Canada
Un organisme
d'Industrie Canada

Canadian
Intellectual Property
Office
An agency of
Industry Canada

Registration Number:
Date of Registration:

155383
2015-05-26

MULTISPACE PARKING PAY STATION

Applicant(s) as Filed: **IPS Group, Inc.**

Description:

The Design consists of the features of shape, configuration, and ornament of the MULTISPACE PARKING PAY STATION as shown in solid lines in the drawings. Portions shown in stippled lines do not form part of the design. Drawings of the Design are included, in which: Figure 1 is a front elevational view of the MULTISPACE PARKING PAY STATION; Figure 2 is a top front perspective view thereof; Figure 3 is a right side elevational view thereof; and Figure 4 is a left side elevational view thereof.

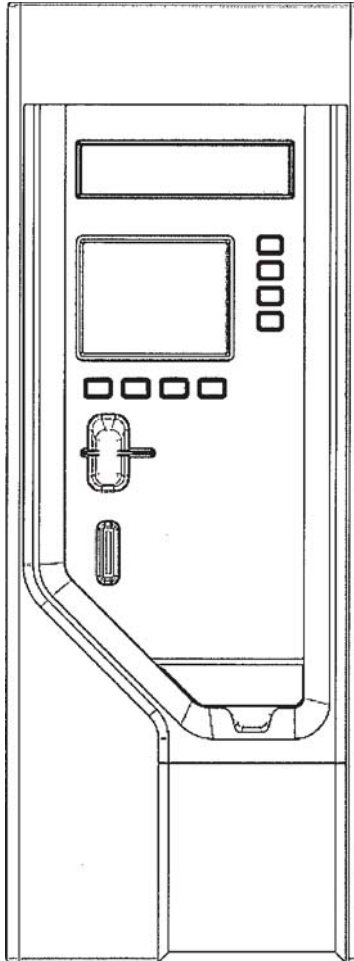

Details

Third-Party Information Liability Disclaimer

Some of the information on this Web page has been provided by external sources. The Government of Canada is not responsible for the accuracy, reliability or currency of the information supplied by external sources. Users wishing to rely upon this information should consult directly with the source of the information. Content provided by external sources is not subject to official languages, privacy and accessibility requirements.

National Application/Registration : 155383

Date of Registration :

2015-05-26

Made available on :

2015-05-26

Status :

Registered

Title or finished article: MULTISPACE PARKING PAY STATION

Canadian Classification:

20-01-AUTOMATIC VENDING MACHINES

Other Classes Searched:

N/A

Description:

The Design consists of the features of shape, configuration, and ornament of the MULTISPACE PARKING PAY STATION as shown in solid lines in the drawings. Portions shown in stippled lines do not form part of the design. Drawings of the Design are included, in which: Figure 1 is a front elevational view of the MULTISPACE PARKING PAY STATION; Figure 2 is a top front perspective view thereof; Figure 3 is a right side elevational view thereof; and Figure 4 is a left side elevational view thereof.

Statement:

N/A

Interested Parties

Applicant(s) as Filed:

IPS GROUP, INC.

Registered Proprietor(s):

IPS GROUP, INC.

5601 OBERLIN DRIVE, SUITE 100

SAN DIEGO, 92121
CALIFORNIA, UNITED STATES OF AMERICA

Proprietor(s):

IPS GROUP INC.
7737 KENAMAR COURT
SAN DIEGO, 92121
CALIFORNIA, UNITED STATES OF AMERICA

Client Reference Number:

83472-21

Representative for Service:

SMART & BIGGAR LLP
2300-1055 WEST GEORGIA BOX 11115
VANCOUVER, V6E 3P3
BRITISH COLUMBIA, CANADA

Agent:

SMART & BIGGAR LLP
2300-1055 WEST GEORGIA BOX 11115
VANCOUVER, V6E 3P3
BRITISH COLUMBIA, CANADA

Registration Expiry date (Subject to payment of a maintenance fee): 10 years

Maintenance Fee Paid:

Yes

Filing Date:

2014-02-26

Correction(s):

No

Priority Claim(s):

1 / 4

FIG. 1

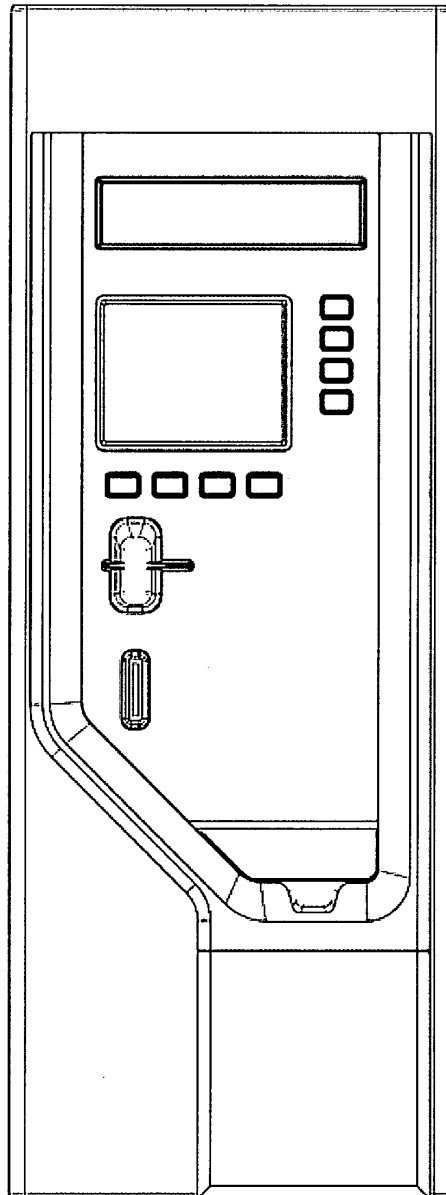

2 / 4

FIG. 2

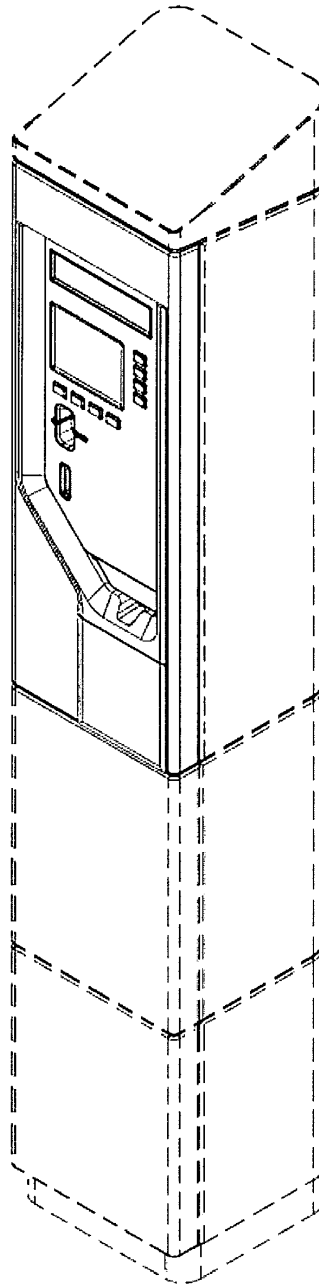

3 / 4

FIG. 3

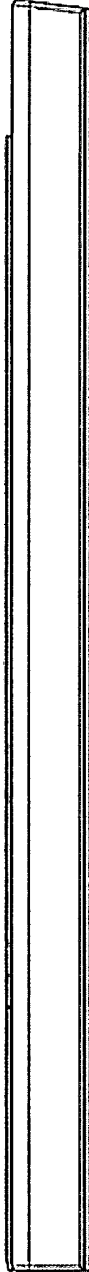

4 / 4

FIG. 4

